



PRO GUIDE

/ RANGE X-ALPS3

CONTENT

1	Introduction	35
2	Description	36
3	Safety Notice	37
4	Features	38
5	Mounting the Reserve Chute	42
6	Initial Setup	47
7	Harness Adjustments	50
8	Replacement of Individual Parts	52
9	Flying Safe	53
10	Operating Limits	55
11	Maintenance, Care	57
12	Repairs	59
13	Disposal	59
14	Homologation	59
15	Maintenance Check	60
16	Technical Data	60
17	Nature and Environmental Friendly Behaviour	61
18	Closing Words	61
19	Test Protocol	62



1 INTRODUCTION

Welcome to skywalk!

Congratulations on the purchase of your new RANGE X-ALPS3 and thank you for your trust in us and in our products. In this manual you will find information that will help you quickly get to know your new harness to ensure your fun for a long time.

At skywalk we are enthusiastic about wind sports and innovative technologies.

When we founded skywalk in 2001, our goal was to make paragliders and kites that offer new solutions to set new impulses, and to provide customers with a maximum of user friendliness. Today we are one of the most successful paraglider manufacturers in the world.

For this we are thankful for our curiosity about everything that flies, sails and surfs, as well as our interest in a variety of outdoor sports. It's this "big picture" view that allows us to continuously set new accents in paragliding.

We are always open for questions, comments or critique and are happy to provide you at any time with further information!

Your skywalk Team
PURE PASSION FOR FLYING

Edition 1.0 /02_2023
The latest version of the manual can be found on
www.skywalk.info

2 DESCRIPTION

The RANGE X-ALPS3 is a ultralight pod harness, designed for pilots who focus on aerodynamic flying, high comfort over long distances, low weight & pack size and reliable safety thanks to PERMAIR technology.

The lightweight design requires a certain amount of caution in handling.

The PERMAIR protector combines the advantages of foam and ram air protectors. PERMAIR offers maximum damping with minimal weight and pack size.



THE TYPE CERTIFICATE AND THE DATE OF THE FACTORY INSPECTION CAN BE FOUND IN THE UPPER PART OF THE V-LINE CHANNEL, THEY ARE ACCESSIBLE VIA THE ZIPPER. SHOULD THIS BE MISSING, ASSUME THAT THIS HARNESS IS A PROTOTYPE THAT HAS NOT BEEN TESTED.

SCOPE OF DELIVERY

- Harness with extensive accessories:
- Two-level speedbar
- Inflation Bag
- 2 pieces carabiner Edelrid Foras
- Carbon foot plate
- PERMAIR protector RANGE X-ALPS3
- Inflate/Deflate valve
- Rescue handle
- PERMAIR mouthpiece



3 SAFETY NOTICE

With the purchase of this equipment, you assume the full responsibility and accept all risks associated with the use of paragliding equipment, including injury and death. Improper use of paragliding equipment increases this risk. To fly a paraglider, you must be in possession of the required license or permit for the country in which you are flying. Neither skywalk nor the seller nor the importer of this product can be made liable in case of personal injury or damage caused to a third party.

LIABILITY AND WARRANTY EXCLUSIONS

If any of the following cases apply, the harness may not be flown under the terms of the warranty and liability rules:

- In the event of any modifications to the harness that are not within the tolerances allowed by the manufacturer.
- In case of improper repairs.
- If the inspection period has expired, or if the inspection is carried out by unauthorized persons.
- Winch launches on winches that have not been inspected.
- In case of insufficient license of the pilot or winch operator for winch launches.

SAFETY NOTICES

If a product is found to be defective in operation which may affect other specimens of a type, safety notices are issued. These notices will be published on the skywalk homepage and on the homepage of the respective type testing station. Safety notices contain instructions on how to check the equipment for possible defects and what measures are required to remedy the respective defect.



THE IMPLEMENTATION OF THE MEASURES FROM THE SAFETY NOTICES IS THE RESPONSIBILITY OF THE OWNER OF THE PRODUCT.

4 FEATURES

- 1 - Double action carabiner Foras from Edelrid**
Lightweight twist and push carabiner with side opening gate for easier riser installation.
- 2 - Front rescue system with cockpit**
The cockpit offers space for several flight instruments and is optimally positioned in the pilot's field of vision.
- 3 - Nitinol Power Frame**
Provides ideal pressure distribution and support for the seat shell.
- 4 - In-flight adjustments**
 - a) Shoulder strap: For adjusting to the torso length.
 - b) Back angle: Adjustment of pilot position and angle in flight.
- 5 - Carbon foot plate**
- 6 - Opening for urinal tube**
- 7 - Accelerator opening**
- 8 - PERMAIR Protector**
LTF 91/09 certified protector. Maximum protection at minimum packing size and weight.
- 9 - PERMAIR valve**
The valve enables effortless inflating and deflating of the protector.

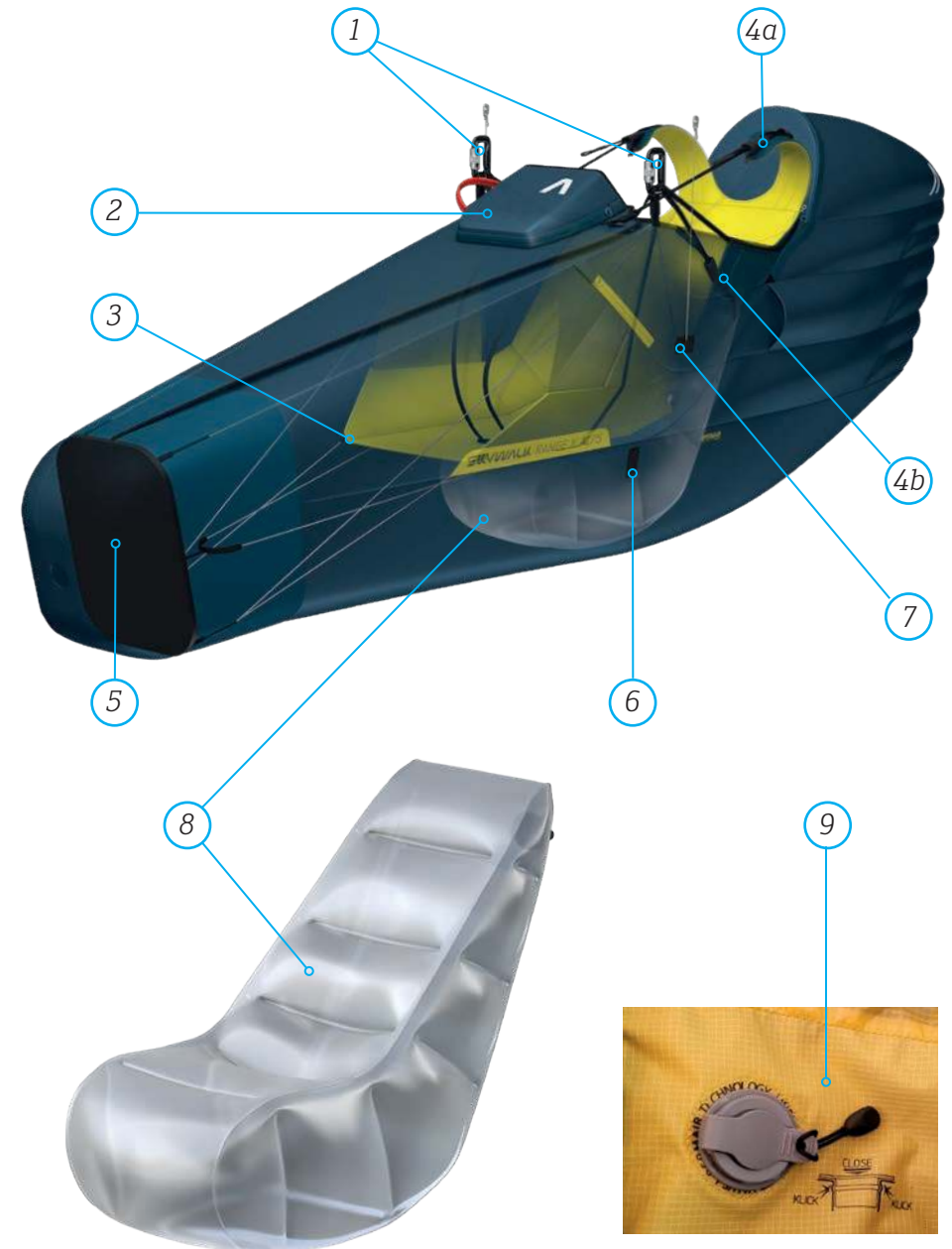

10 - Cockpit pocket

Located on the inside of the front container.

11 - Lycra inner pocket & lockable side pocket

Ideal for items which must be reached during the flight.

12 - Pole pocket

Ensures easy and safe storage of foldable hiking poles.

13 - Storage compartment "nose"

Also serves as a storage compartment for light, soft objects such as clothing, inner bag, inflation bag etc.

IMPORTANT: Load with max. 1kg! Pay attention to the shape because the nose doesn't inflate anymore! Handle with care!

14 - Storage compartment "seat"

17l capacity. Load with max. 5kg!

15 - Back storage compartment

35l capacity. Asymmetric zip for easy filling.

Ideal to stow a backpack.

16 - RECCO®-Reflector

The RECCO®-reflector offers emergency personnel an additional chance to locate a missing person (for example in heavily forested areas).

17 - Velcro

For solarario or radio. Incl. safety loop.

18 - Provision for hydration system

Includes a clip in the back storage compartment for hydration bladder attachment, a drinking tube outlet and a neoprene loop on the shoulder strap for attaching the mouthpiece.

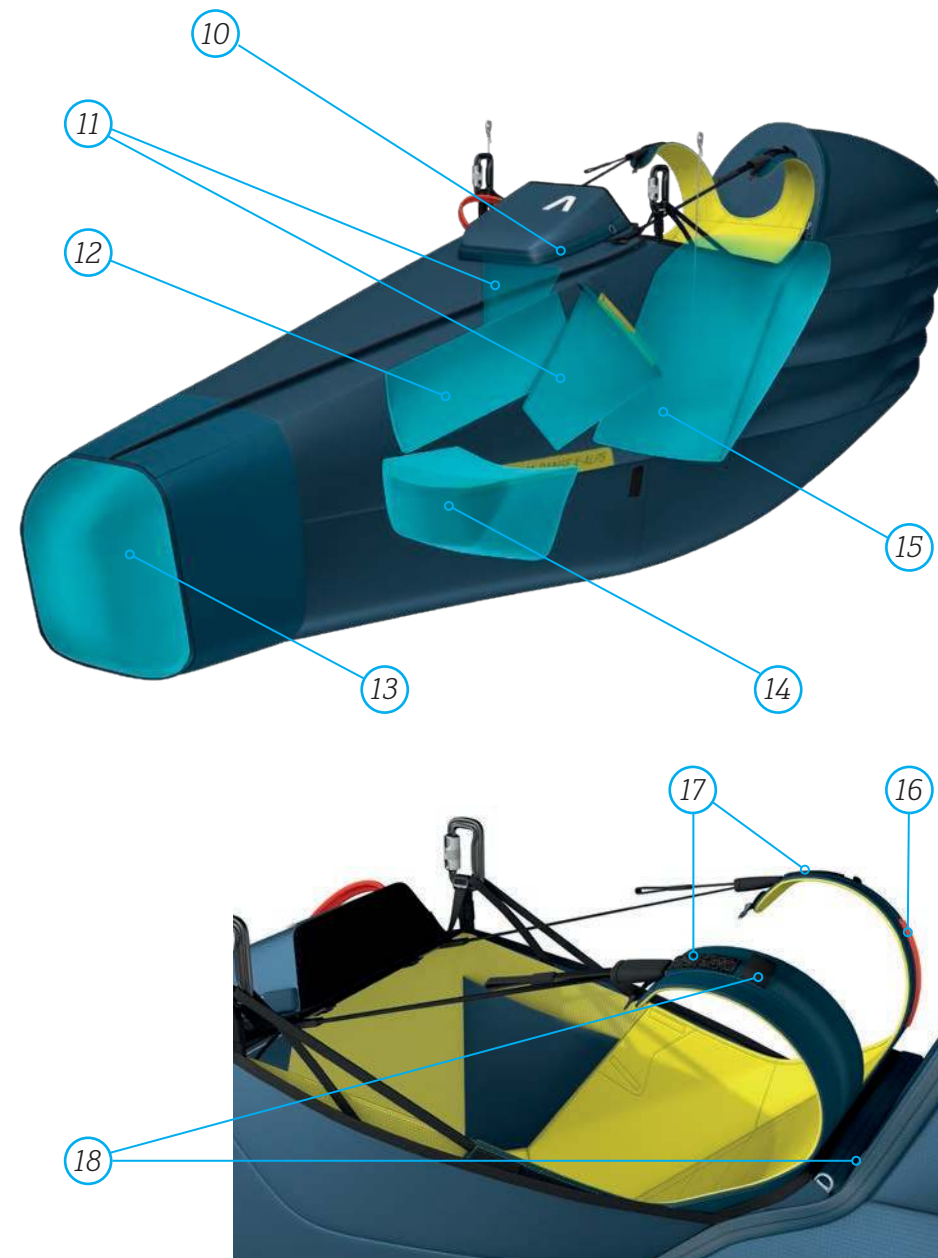

5 MOUNTING THE RESERVE CHUTE

The RANGE X-ALPS3 can be combined with most lightweight reserve chutes. The reserve chute may only be integrated in the front container, keeping aware of the maximum volume of the reserve chute. The maximum allowed volume must not be exceeded, otherwise a correct deployment cannot be guaranteed. The initial installation of the reserve chute must be carried out by an approved compatibility technician.

This verifies the deployability of the reserve chute and certifies its compatibility on the reserve chute's packing and inspection document.

It is very important that the test release of the rescue device is carried out by the pilot himself sitting in the harness in a harness simulator, as different physiques and forces affect its deployability. Before installation, you must first check whether the reserve chute needs to be repacked.

CONNECTING THE RESERVE CHUTE WITH THE HARNESS

1. Connect the rescue handle with the inner container of your rescue chute. Use the outer loop of your inner container



2. Now you can connect the V-lines of the RANGE X-ALPS3 with the lanyard of your reserve chute.

To connect the reserve chute to the V-line, you must use a screw shackle with at least 2400 daN strength.

The lines have to be connected on both sides of the screw shackle and must be secured with rubber bands. As an alternative, you can connect the two lines with softlinks if the size of the loop on the reserve chute allows this. Looping your reserve chute with the V-lines is reliable and safe using skywalk products when you comply with condition such as



maximum tightening of the straps and looping in the center.

We cannot make a binding statement about the strength behavior when looping with reserve chutes of other manufacturers.

3. Finally, secure the connection with the cover by placing the cover centrally over the connection.



INSTALLING THE RESERVE CHUTE

1. Place the rescue with the lines looking upwards in the rescue compartment of the RANGE X-ALPS3 and the V-line untwisted next to it. Guide the V-line upwards in the lateral channel. The rescue handle is pointing to the right side in flight direction.
2. Guide the zipper slider counter the actual functional direction to the opening of the rescue compartment until the slider touches the stopper and place the connection strap of the inner container between the stopper of the zipper and the loop on the front container, so that the rescue is in the rescue compartment and the handle is on the outside of the harness. The zipper must remain in this position until the end.
3. After the rescue is correctly placed in the harness, it must be closed by means of the cotter pins on the rescue handle. To do this you need two



short auxiliary lines (due to the low friction we recommend unsheathed, not too thin paraglider lines or rigid foils), which you thread into the two loops on the front container. Pull the two loops through the two eyelets with the help of the auxiliary lines.

4. Secure the two loops with the cotter pins on the rescue handle.
5. Insert the ends of the cotter pins into the channels .
6. Secure the handle in the neoprene pockets, making sure that the handle is not twisted and that the Velcro is in the correct position.
7. Pull off the auxiliary lines carefully and slowly. Moving too quickly could damage the loops.
8. The slider of the zipper must still touch the stopper, guide it back into position in case it has slipped. Close the zipper completely, making sure it disappears completely into the zipper garage



STEERABLE RESCUE PARACHUTES

The RANGE X-ALPS3 can also be used with steerable reserve parachutes, provided that the specified volumes are observed. To assemble the rescue system, two screw carabiners with a total tensile strength of at least 2.400 daN are directly connected to the color-coded suspension points in the upper part of the V-line channel.

The control handles of the rescue system can be stored in the small compartment in the upper part of the V-line channel. The straps are routed from the V-line channel into the rescue compartment. The unused serial V-line can remain in the upper part of the V-line channel.

During assembly, make sure that the control handles of the rescue parachute fit in the upper part of the V-line channel and do not come into contact with the inner container.

COMPATIBILITY TEST

The correct installation of the reserve chute should now be verified with a test deployment. To do this, put on the harness, close the leg straps and hang the main carabiners in a harness simulator. Then pull out the reserve chute by the handle.

For this test, it is not enough to deploy the reserve chute without sitting in the harness. It must be possible for you to reach and pull the handle with no problem from the flying position, in accordance with the instructions of this manual. The deployment force must not be below 2 daN and must not exceed 7 daN. In case of uncertainties you should consult a specialist or contact your competent skywalk dealer.

The reserve chute must be deployed with the correct throwing technique, with a continuous and steady pull in a sideward movement away from the harness. Otherwise, deployment may be difficult.



BEFORE EACH FLIGHT, CHECK TO SEE IF THE RESCUE HANDLE IS IN THE RIGHT POSITION AND WHETHER THE SPLINTS OF THE HANDLE ARE SITTING CORRECTLY. REACHING FOR THE RELEASE HANDLE TO TEST ITS POSITION EVERY FLIGHT CAN HELP YOU MEMORIZE THE POSITION SUBCONSCIOUSLY.

DEPLOYMENT OF THE RESCUE PARACHUTE

In the design of the release unit, the highest value was placed on ease of release. The rescue release was checked in numerous tests in the G-Force simulator. When releasing the rescue, pay attention to the direction of movement. Here you will find an overview of ideal and rather unfavourable directions:

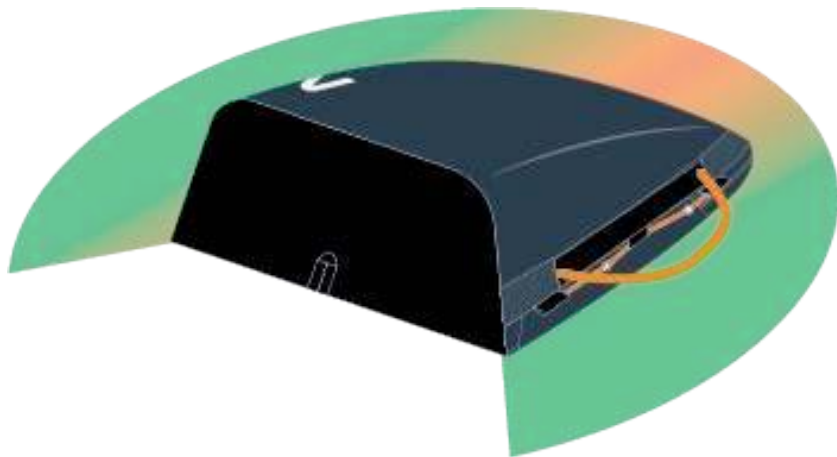

green = very good
orange = moderately difficult
red = adverse
due to seat position and arm length

A reserve chute deployment can be made more difficult by the following factors:

- The reserve chute is too large or too bulky for the compartment or the deployment bag.
- The reserve chute is not packed in the shape of the deployment bag.
- The reserve chute is not thrown with the appropriate throwing technique.
- The reserve chute has too much volume after repacking.
- Because arm length is crucial for a successful reserve chute deployment, smaller persons with short arms may not be able to deploy the reserve chute.
- In emergency situations, high G-loading can occur, which can make deployment even more difficult.

6 INITIAL SETUP

SPEED SYSTEM

The supplied speed system is already mounted on the seat of the harness when delivered. However, the length of the speed bar travel must still be set individually on the paraglider. Proceed as follows:

1. If the speed system is set too short, it won't be possible to fully extend your legs.
2. If the speed system is set too long, the pulleys on the risers will not meet.
3. In the optimal case, your legs are stretched out fully just as the pulleys on the risers of the paraglider touch each other.
4. To adjust the length, open the knot on the brummel hooks.
5. After finding the optimal length, tie the brummel hook with a bowline knot.
6. You can also adjust the second step of the speedbar by means of a knotted line.

PERMAIR PROTECTOR

The RANGE X-ALPS3 is a harness with permanent-airbag protector. The protector is approved according to the rigorous criteria of LTF91/09 and meets these requirements when inflated. The protector provides the best protection when fully inflated and can be inflated with the Inflation Bag, the PERMAIR mouthpiece or the PERMAIR pump (optional). skywalk recommends to use any of the three inflation aids mentioned above, as the humid air you breathe can lead to condensation, which in turn encourages the formation of mold.

The protector can be removed behind the storage compartment underneath the seat to make any repairs. Make sure to keep sharp objects, such as sticks, away from the harness.



THE PROTECTOR IS NO SEAT CUSHION! SITTING ON THE HARNESS MAY DAMAGE THE PROTECTOR OR SHORTEN ITS LIFE. IF YOU SUSPECT DAMAGE, TEST FOR LEAKS. WHEN IN DOUBT, CONTACT YOUR SKYWALK DEALER OR US DIRECTLY.

INFLATION BY INFLATION BAG

1. Make sure that there are no sharp or pointed objects on the ground.
2. Lay the harness flat on its side and make sure that there are no heavy objects on top of the protector, making inflation difficult.
3. Open the back compartment.
4. Insert the valve into the valve base, making sure that the valve closes completely and no gap remains. If the check valve is not yet fully seated in the base, press the valve into the base with both thumbs until a slight click is heard and no gap is visible between the valve and the base. This can be a little more difficult in colder temperatures, such as

in winter, and you should pay particular attention to this when the temperature is below 10°C.

5. Connect the PERMAIR connector of the inflation bag to the valve and make sure that the connection of the inflation bag is not twisted.
6. Open the roll-top of the inflation bag. Blow into the opening from a distance of about 20cm and close the inflation bag by rolling the opening until pressure builds up inside.
7. Apply more pressure by pumping the inflation bag so that air flows into the PERMAIR protector.
8. You will feel a pressure increase in the inflation bag when the protector is completely filled. It is not possible to pump more air into the protector. The check valve will ensure that no more air escapes.
9. Repeat steps 6-8 if the protector is not completely filled.
10. Close the valve with the safety cap.



THE PROTECTOR IS ONLY LEAKPROOF WHEN THE BACK PRESSURE VALVE SITS COMPLETELY IN THE VALVE BASE. DUE TO THE TEMPERATURE DEPENDENT MATERIAL BEHAVIOR, IT IS POSSIBLE THAT THE VALVE IS HARD TO CLOSE AT TEMPERATURES BELOW 10°. IN ORDER TO STILL CLOSE THE VALVE, IT IS HELPFUL TO PLACE THE HARNESS ON A HARD BUT SMOOTH SURFACE AND THEN APPLY PRESSURE WITH BOTH THUMBS ON THE INNER RING OF THE VALVE.

INFLATION BY PERMAIR MOUTHPIECE

1. Follow step 1-4 from the description above.
2. Connect the grey part of the mouth piece to the valve.
3. Make sure the HME-filter (heat moisture exchanger) is inside the mouth piece (blue sponge) and start with inflating by blowing inside the transparent opening.
4. The protector is fully inflated once you feel significant resistance of air pressure when blowing inside.



AFTER USING THE MOUTHPIECE MAKE SURE IT DRIES OUT COMPLETELY BEFORE YOU STORE IT AGAIN. FOR HYGIENIC REASONS PLEASE REPLACE THE MOUTHPIECE AFTER TWO YEARS OR IF YOU SEE ANY SIGNS OF MOLD.

INFLATION BY PERMAIR PUMP

1. Follow step 1-4 from the description „Inflation by Inflation Bag“.
2. Put the PERMAIR adapter of the pump on the pump outlet (grey adapter).
3. Connect the pump outlet to the valve.
4. The pump can now be easily switched on via the On/Off switch. When filling, make sure that the protector is not twisted.
5. As soon as the pump pressure corresponds to the PERMAIR protector pressure, the pump cannot pump any more air into the protector and you can switch off and disconnect the pump. The check valve prevents the air from escaping.



THE PUMP PRESSURE DEPENDS ON THE CHARGE LEVEL OF THE PUMP BATTERY. WITH A FULLY CHARGED BATTERY, THE PUMP CAN BE USED ABOUT 20 TIMES BEFORE IT NEEDS TO BE RECHARGED. AS A BACKUP, YOU SHOULD ALWAYS HAVE THE PERMAIR MOUTHPIECE WITH YOU TO INCREASE THE PRESSURE IN THE PROTECTOR IF NECESSARY.



FOR FLIGHTS WITH AN ALTITUDE DIFFERENCE OF MORE THAN 1500M BETWEEN TAKE-OFF AND LANDING SITE, THE PROTECTOR MUST BE ADDITIONALLY INFLATED WITH THE MOUTHPIECE.

PACKING AND COMPRESSING

To deflate the protector, simply pull the valve out of the valve base. Afterwards, the RANGE X-ALPS3 can be folded in half and stored in the inflation bag provided. It is not necessary to deflate the protector after each flight. You can also stow the harness inflated in the backpack for several flights per day, provided the backpack is large enough. Nevertheless, the filling level of the protector must be checked before each flight during the pre-flight check and adjusted if necessary.

HOOK IN THE PARAGLIDER

Between the paraglider and the harness there are two connection points per side (main suspension and speed bar line). Make sure that both risers of the paraglider are connected to the carabiners of the harness without twisting and that the carabiner is fully closed. In addition, the speed system of the paraglider must be connected to the speed bar of the harness via the Brummel hooks. It is important that the speed bar line runs freely along the outside of the harness without any obstacles. The proper connection between the harness and the paraglider must be carefully checked before each launch.

7 HARNESS ADJUSTMENTS

Together with your dealer, the RANGE X-ALPS3 is adjusted and checked. You will then make the basic adjustment yourself while sitting in a harness simulator.

Follow these steps to put on the harness:

1. Slip your arms through the shoulder straps.
2. Close the Get Up system (blue stitching right und red stitching left).
3. Lead the right ball (A) through the left loop (B) on the cocoon.
4. Guide the line on the left side (1) through the right eyelet (2) on the cocoon and lead the toggle (3) of the safety line on the Get-up system through the loop of the line.

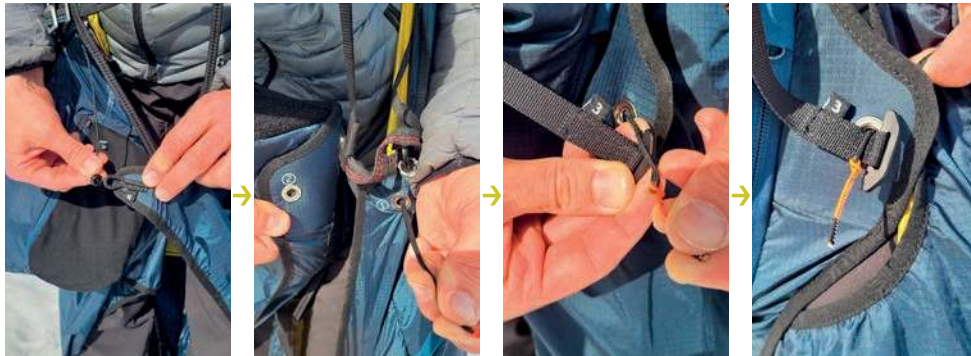

ADJUSTMENTS

The RANGE X-ALPS3 offers the pilot the possibility to adjust the seating position as well as the length of the cocoon.

Shoulder strap

The shoulder strap adjusters are used to adjust the harness to the upper body length of the pilot. It should be noted that clothing during flight is also taken into account. The length should be adjusted so that the shoulder straps make light contact with the top of the shoulders in the flight position. A slight tension on the shoulder straps can improve back support, but if the tension is too tight, it can cause fatigue in the shoulder muscles.

Back tilt

You can make an initial pre-setting of the seat position in the harness simulator. During the test flight you can fine tune the back angle, because the airflow changes the angle of the harness by 3-4° due to the air resistance. The Edelrid adjusters attached to the RANGE X-ALPS3 fix themselves automatically, for adjustment they are best relieved.

Lumbar support

A knotted line leads below the back tilt adjustment to the main suspension for fine adjustments of the lumbar area.

Upper leg support

A knotted line leads from the forward seat area to the main suspension for fine adjustments of the upper leg area.

Cocoon

The length of the cocoon can be adjusted by means of a knotted line at four points on the foot plate. The Lycra insert in the front part of the cocoon provides enough clearance. For each knotted line, three length are possible. The top line leads to the upper loop on the footplate, the bottom and diagonal lines lead to the lower loop. The diagonal lines assist as additional support.



TO PREVENT UNNECESSARY WEAR AND TEAR OF THE LYCRA, IT IS PROHIBITED TO LENGTHEN IT BEYOND THE RANGE OF THE KNOTTED LINE.

Stabilizer

You can mount a stabilizer in case you would like to make your RANGE X-ALPS3 even more stable, for example when flying with a high performance wing.

There are two loops on each side where you need to mount the supplied line. One loop is at the inside on the sidecover of the seatshell, here you need to loop the line. The other loop is next to the buckle of the Get-up system, here you mount the end with the screw shackle.



8 REPLACEMENT OF INDIVIDUAL PARTS

PERMAIR protector

The protector can be removed from the harness to perform a leak test or for replacement. After every hard landing as well as every impact from a height of more than 0.5 m, a leak test must be performed on the protector.

Carabiner

When replacing carabiners, make sure that both webbing loops (back support/main suspension) are passed through the carabiner.

Carbon foot plate

Use of the RANGE X-ALPS3 in extreme or acrobatic flight maneuvers is not recommended. If the foot plate is damaged, it can be replaced.

1. Remove the damaged foot plate from the compartment. This requires a bit of effort, do not use a tool!
2. Insert the new foot plate.



BROKEN CARBON PARTS USUALLY HAVE AN OPEN FRACTURE EDGE WITH MANY SHARP POINTS. USE GLOVES AS A PRECAUTION AND AVOID CONTACT WITH THE FRACTURE EDGE. IF CARBON FRAGMENTS GET UNDER THE SKIN, THIS CAN LEAD TO INFLAMMATION.

Accelerator

In case of excessive wear or damage of the accelerator, it is possible to replace the accelerator in the following steps:

1. Open the bowline knot of the accelerator line on the Brummel hook.
2. Open the bowline knot of the elastic line which leads from the accelerator to the foot plate.
3. Now the old accelerator can be disassembled.
4. Thread the main line through the accelerator pulley from bottom to top.
Make sure that the line is guided on the outside of the main suspension and not between main suspension and the seat.
5. At both ends of the main line, the Brummel hooks can be fixed to the desired position with a bowline knot.
6. Connect the elastic line from the foot board with the accelerator using a bowline knot.

9 FLYING SAFE

PREFLIGHT CHECK

It is important to check all paragliding equipment thoroughly before every flight to see if it has any defects. Also check the paraglider after long flights and after long storage.

Check thoroughly that:

- No visible damage to the harness or carabiners is present that can affect airworthiness.
- The reserve parachute container is correctly closed and is connected to the harness, that the splints are threaded completely through the loops and that the rescue handle is correctly mounted.
- All buckles, straps and zippers are shut and secured.
- The paraglider is correctly hooked to the harness and that both carabiners are correctly closed and secured.
- The speedbar is properly hooked into the speed system of the risers.
- All pockets are closed and that no loose items are hanging around.
- The protector is filled.
- All leg and chest straps are closed before you launch!



DO NOT LAUNCH IF YOU FIND ANY DEFECTS, EVEN SMALL ONES!
IF YOU FIND ANY SIGNS OF DAMAGE OR ABNORMAL WEAR AND TEAR,
CONTACT YOUR FLIGHT SCHOOL OR SKYWALK DIRECTLY.

BEHAVIOR IN THE EVENT OF A RESERVE CHUTE DEPLOYMENT

- Locate the rescue handle at the harness and hold it tightly with one hand.
- Pull the handle firmly away from the harness in a continuous and a sideward movement to release the split pins and pull out the reserve chute.
- Make sure that you throw the reserve chute in the deployment bag into free airspace.
- If possible, throw it in the opposite direction of any rotational movement and let go of the handle!
- Once the reserve chute is open, try to keep it from tangling and swinging. It is best using the B-, C-, D- or the brake lines to pull the glider symmetrically toward you.
- When you land, straighten up as much as possible and use the parachute landing fall (PLF) technique to minimize the risk of injury.

WHAT TO DO IN EMERGENCY SITUATIONS AND EXTREME FLIGHT CONDITIONS

Disturbances of the paraglider that are caused by thermal lift or turbulence are transmitted perceptibly via the harness mounts to the seat.

To avoid getting tipped to the side, make sure that you are always sitting in the middle of the harness. Also make sure that you don't lose your grip on the brake handles so that you can react quickly and without delay to extreme flight conditions. Read about the behavior of your glider in extreme flight conditions in the appropriate manual.

Should you fly into an object or land in a tree, be calm and notify the authorities.

FLYING ON BAR

The speed bar should be secured to the harness prior to launch. To use the speed bar, you will need to make some effort. This can affect the sitting position in the harness.

Therefore, we recommend an upright position in the harness. Adjust the harness before your first attempt of flying on bar. We remind you to only fly in wind conditions that don't require constant use of the speed bar. To reach the maximum speed, press the speed bar firmly until both pulleys on the A-risers touch each other.

As soon as you apply the speed bar, the angle of attack will be reduced and the speed increases, but the paraglider becomes less stable and can collapse more easily.

For this reason, always use the speed bar with adequate altitude over the ground and distance from obstacles and other aircraft. Avoid adjusting the speed bar too short.

It is important to avoid unintentionally activating the speed system due to a setting that is too short. Collapses on bar are normally more impulsive and demand fast reactions.



NEVER FLY ON BAR IN TURBULENT AIR.
NEVER FLY ON BAR NEAR THE GROUND.

10 OPERATING LIMITS

The harness may only be flown within the operating limits. This limit is exceeded as soon as one of the following occurs:

- Flying outside the maximum permissible take-off weight.
- Flying in the rain, in snowfall, in extremely turbulent weather conditions or in strong winds.
- Flying in clouds or fog (visual flight).
- Flying with insufficient pilot experience.
- Flying with multiple seats.
- Flying with wet canopy.
- Flying in temperatures below -15°C and above 50°C.
- Aerobatics (flight maneuvers with an inclination of more than 135 degrees).

The RANGE X-ALPS3 is approved according to DIN EN 1651 for a maximum pilot weight of 120 kg. Due to the higher stress on the material, it is strongly discouraged to fly extreme flight or acro maneuvers.

The Edelrid Foras carabiner is a lightweight product and requires special care:

- Do not use the carabiner if there is any visible external damage or wear.
- Avoid transverse loads, strokes and do not drop the carabiner.
- The carabiner should be replaced after 5 years or 500 hours.

WINCH-TOWING

The RANGE X-ALPS3 is suitable for winch towing. It has no special towing loops. The tow release is hooked either to the main carabiners or, preferably, to a towing adapter which is passed over the ends of the risers before they are hooked into the main carabiners. Follow the instructions in the manual for your tow release and tow adapter or consult a flight instructor who has experience with winch-towing.



SKYWALK EXPRESSLY WARNS OUT THAT TURNING THE MAIN CARABINER AROUND TO POINT OPPOSITE THE DIRECTION OF FLIGHT IS STRICTLY PROHIBITED! REASON: THE DESIGN ADVANTAGES OF THE HIGH SUSPENSION POINT AND CONTINUOUS BACK SUPPORT COULD CHAFE AND DAMAGE THE LOCKING MECHANISM OF THE CARABINER.



TANDEM FLIGHT

The RANGE X-ALPS3 is not a suitable harness for tandem flight.

SAFETY TRAINING AND FLYING OVER WATER

It is not recommended to use the RANGE X-ALPS3 for flights over water or for safety training. There is a possibility that the PERMAIR protector could push the pilot under water after a water landing due to the buoyancy of the protector. Should you nevertheless use the harness for flights over water, we explicitly advise you to wear a life jacket.



BE CAREFUL WHEN FLYING OVER WATER!

LIFETIME

The harness is your direct connection point to your paraglider. You are responsible for checking the harness before each use. If you have any doubts about its safety, do not use the harness under any circumstances and contact your skywalk dealer.

All webbing, thread, cloth and hardware have a limited life span. To determine if your harness is still safe, you should inspect it according to the inspection protocol attached at the end of this manual. skywalk harnesses that are properly stored and meet all inspection criteria can be used for up to 10 years from the sample inspection date.

You can find the sample inspection date on the sample inspection tag located in the V-line compartment of your harness. Please keep in mind that some factors that affect the life of your harness are not visible.

You should know the full use history of the harness. You should know what environmental influences (UV light, salt water, extreme heat, etc.) or chemical influences (aggressive cleaners, petroleum, oils, lubricants, acids, etc.) the harness has been exposed to.

If the harness has been subjected to a great deal of stress, such as a rescue deployment, crash, or tree landing, it should no longer be used and should be destroyed immediately.

Dispose of harnesses that are obsolete due to new regulations or standards, or that are incompatible with other safety system equipment. It is your responsibility to know these factors. If there is any doubt about its condition, you should stop using the harness and destroy it.

11 MAINTENANCE, CARE

The selected materials used in the RANGE X-ALPS3 make it necessary to treat them carefully and in a professional manner. Make an effort to take care of your harness and keep it clean to preserve its airworthiness over the longest possible time.

- Avoid dragging your harness over stony ground and always try to land in an upright position.
- Don't leave your harness lying in the sun unnecessarily long. UV radiation is very damaging to the material.
- Store it in the bag when you don't use it.
- Store your paragliding equipment loosely packed in a cool and dry place. If it gets wet always dry out your equipment before packing it.
- To clean it, just use a brush or a damp cloth. Use mild soap to clean it only when absolutely necessary. If you do, first remove other parts like the reserve parachute. The coating of the material can be damaged by brushing or rubbing.
- Let the harness dry in a well-ventilated, shady place if it was wet. If the reserve parachute gets wet, (e.g. during a water landing), then it is necessary to open it up, let it dry, and pack it again.
- After a hard landing or an impact higher than 0.5m, check the protector for damage.
- Zippers should be treated with silicon spray once a year.

MATERIALS

The skywalk RANGE X-ALPS3 is extremely weight-optimized and made exclusively from high-quality materials. skywalk has selected the best possible combination of materials in terms of resilience, weight and durability.

We are aware that the durability of the equipment is one of the decisive factors for the satisfaction of the pilot, but due to the choice of material and construction of the harness we would like to point out that the harness is more prone to wear and damage if used improperly.

The lifespan of this product is highly dependent on your mindfulness.

The following activities can significantly reduce the lifespan of your RANGE X-ALPS3:

- Acrobatic flight maneuvers
- (Coastal) soaring with permanent touch & go
- Extensive ground handling
- Improper handling of the equipment

MAINTENANCE CHECKLIST

In addition to your normal preflight procedure, you should also take a close look at your RANGE X-ALPS3 after the reserve parachute has been packed and re-installed – normally every six months but no later than every twelve months. Naturally, it's important to also check your harness closely after unusual circumstances, for example after a hard landing or a tree landing, or if the harness shows above-average wear and tear. When in doubt, always consult an expert.

Here is what to check:

- Check all straps and buckles for wear and tear and damage.
- The stitching of all seams should be checked and, if in doubt, should be repaired to keep problems from propagating.
- Both carabiners should be renewed after no more than 5 years or maximum 500 flight hours. Impact to the carabiners can result in invisible damage that could lead to failure during use.
- Perform a leak test for the PERMAIR protector.

The documentation for service work should be entered with the name of the repair person, stamp and signature.

LEAK TEST

After a hard landing or fall from a height of more than 0.5m, a leak test should be performed on the protector in order to be able to detect any damage before the next flight and to remedy it subsequently.

Follow these steps:

1. Remove the protector from the harness.
2. Inflate the removed protector so that the outer edges of the nameplate measure 83mm.
3. Store the protector at a constant temperature for 12 hours in a shady room.
4. After the time has elapsed, check the fill level of the protector by measuring the outer edges of the nameplate again. The length must not be less than 81mm.
5. If the protector meets the requirements under point 4, it can be reinstalled.

STORAGE

Ideal is a dry, dark place with a constant temperature. Moisture is an old enemy of the durability of all paragliding equipment. For this reason, always dry your equipment before you store it, preferably in a heated and well ventilated room, so that moisture can evaporate. Make sure the inflate/deflate valve of the PERMAIR protector remains open when storing the harness for a longer period.

12 REPAIRS

Repairs should only be carried out by the manufacturer or by an authorized skywalk service center. Exceptions include the repair of small cuts (up to about 3cm that don't affect a seam).

CHANGES TO THE HARNESS

Your skywalk RANGE X-ALPS3 is manufactured within the regulated parameters of tolerance. These parameters are very narrow and must not be altered under any circumstance.



UNAUTHORIZED CHANGES INVALIDATE THE TYPE APPROVAL AND ALL LIABILITY CLAIMS AGAINST THE MANUFACTURER AND ITS DISTRIBUTORS ARE INVALIDATED.

13 DISPOSAL

When choosing materials, skywalk places high value on environmental compatibility and the highest quality control. Should your harness someday no longer be flyable, remove all metal parts. All remaining parts can be turned in at a recycling center. The metallic parts can be turned in at a metals recycling center. The best solution is to send your retired skywalk harness directly to us. We will then take care of recycling it.

14 HOMOLOGATION

The RANGE X-ALPS3 is certified to EN as well as LTF standards

The RANGE X-ALPS3 is defined as a lightweight sport aircraft with an empty weight of less than 100 kg in the paraglider category.

The many homologation tests are the last hurdle in the development of a skywalk harness. The homologation tests only take place when the test team is completely happy with the harness development.

15 MAINTENANCE CHECK

According to LTF regulations your harness will have to undergo a maintenance check after 24 months. The maintenance check has to be carried out by the manufacturer or its representative.



IF THE HARNESS IS SUBJECTED TO ABOVE AVERAGE WEAR AND TEAR (EXTREME FLIGHT MANEUVERS, FORBIDDEN ACROBAT FLIGHT MANEUVERS) IT SHOULD BE INSPECTED EARLIER OR SHOULD UNDERGO AN ADDITIONAL INSPECTION!

16 TECHNICAL DATA

Size	S	M	L
Pilot height (cm)	160-176	173-184	183-200
Suspension points height (cm)	45	47	49
Width chest strap (cm)	42	46	46
Weight (g)	1950	2050	2100
Maximum load	120kg		
Harness certification	EN 1651:2018 + A1:2020		
Protector certification	LTF NfL 2-565-20		
Volume rescue container (cm³)	4300	4300	4300

MATERIALS

Fabric cover	TX-Light; N.70 Robic 3mm Double R/S; N.70 Robic Plain Double R/S; Nylon 215D stretch
Webbing	10mm & 15mm Dyneema
Main carabiner	Edelrid Foras
Connector	Frame buckle
Foot plate	Carbon sandwich 8mm
Adjuster	Edelrid SB buckle 10mm; 800DaN
V-line	4mm Dyneema
Protector	Thermoplastic polyurethane
Pulleys	Ronstan Orbit 20 BB
Brummel hooks	Finsterwalder
Power frame	2,5mm Nitinol

17 NATURE AND ENVIRONMENTALLY COMPATIBLE BEHAVIOR

We have taken the first step towards ecological awareness with our nature-friendly sport. Especially with our mountain climbers who prefer to climb to the launch site. Nevertheless, we plan on continuing in the same vein. This means specifically: clean up your trash, stay on marked trails and don't cause unnecessary noise. Please help to maintain the balance of nature and to respect animals in their territory.

18 CLOSING WORDS

The skywalk RANGE X-ALPS3 is at the absolute leading edge of development in the market for ultralight pod harnesses. It cost us a lot of time to develop this harness, but it was also a lot of fun. In this development we recognize the challenge of making the right product for every area and individual taste. We are pleased if you notice this during your first flight and if you feel a certain unity with your glider from the very beginning.

The RANGE X-ALPS3 will provide you with plenty of joy over many years if you treat it and care for it properly.

Respect for the demands and dangers of our sport are essential for successful and beautiful flights. Even the safest paraglider or harness can be dangerous due to misjudgments of meteorological conditions or pilot error. Always remember that flying sports are potentially risky and that you are responsible for your own safety.

We advise you to fly carefully and to respect laws in the interest of our sport, because every pilot always flies at his or her own risk!

WE WISH YOU A LOT OF FUN WITH YOUR NEW HARNESS AND ALWAYS HAPPY LANDINGS!!

Your skywalk Team

19 TEST PROTOCOL			Date:
Customer, name:			
Address:		Phone:	
Product type:	Size:	Serial number:	
Certification number:		Last service:	
Manufacturing date:		Date of first flight:	

Checklist:	Result [+/-]	Defects:	Suggestion:
Identification:	<input type="checkbox"/> + <input type="checkbox"/> -		
Main suspension:			
Carabiner cover: (no abrasion / webbing must be completely covered)	<input type="checkbox"/> + <input type="checkbox"/> -		
Main suspension: (no damage / no excessive wear)	<input type="checkbox"/> + <input type="checkbox"/> -		
Webbing at mainseat: (no damage / no excessive wear)	<input type="checkbox"/> + <input type="checkbox"/> -		
Get-up / leg straps: (no damage / no excessive wear)	<input type="checkbox"/> + <input type="checkbox"/> -		
Safety buckles: (100% functional / no cracks)	<input type="checkbox"/> + <input type="checkbox"/> -		
Seams:			
Webbing 15mm Dyneema: (no damaged, frayed or open seams)	<input type="checkbox"/> + <input type="checkbox"/> -		
Webbing 10mm Dyneema: (no damaged, frayed or open seams)	<input type="checkbox"/> + <input type="checkbox"/> -		
Protector shell: (no damaged, frayed or open seams)	<input type="checkbox"/> + <input type="checkbox"/> -		
Rescue system:			
Loops: (no damaged, frayed or open seams)	<input type="checkbox"/> + <input type="checkbox"/> -		
Cotter pins: (no damaged, frayed or open seams)	<input type="checkbox"/> + <input type="checkbox"/> -		
Rescue handle: (no damaged, frayed or open seams)	<input type="checkbox"/> + <input type="checkbox"/> -		
V-Line: (no damaged, frayed or open seams)	<input type="checkbox"/> + <input type="checkbox"/> -		
Frontcontainer: (no damaged, frayed or open seams)	<input type="checkbox"/> + <input type="checkbox"/> -		

Checklist:	Result [+/-]	Defects:	Suggestion:
Fabric:			
Seat: (no damaged seams or cuts on the fabric)	<input type="checkbox"/> + <input type="checkbox"/> -		
Protector cover and harness bottom: (no damaged seams or cuts on the fabric)	<input type="checkbox"/> + <input type="checkbox"/> -		
Denseness test:			
Inflate the protector: (check level after 12h)	<input type="checkbox"/> + <input type="checkbox"/> -		

Condition: <ul style="list-style-type: none"> <input type="checkbox"/> new <input type="checkbox"/> very good condition <input type="checkbox"/> good condition <input type="checkbox"/> used <input type="checkbox"/> very used, still within certification, check within shorter periods <input type="checkbox"/> not usable anymore, doesn't meet certification 				
Repairs:				
<table border="1" style="width: 100%;"> <tr> <td style="width: 70%;">Signature of checker:</td> <td>Date:</td> </tr> <tr> <td>Name of checker:</td> <td>Company stamp:</td> </tr> </table>	Signature of checker:	Date:	Name of checker:	Company stamp:
Signature of checker:	Date:			
Name of checker:	Company stamp:			



SAMARX300

Skywalk GmbH & Co. KG

Windeckstr. 4 | 83250 Marquartstein

+49 (0) 8641/69 48 0

info@skywalk.org | www.skywalk.info

SKYWALK

   PURE PASSION FOR FLYING